

FEDERAL SIGNAL CORPORATION

*Eclipse*⁸
&
Eclipse^{NH}

ELECTRO-MECHANICAL
DC POWER SIRENS

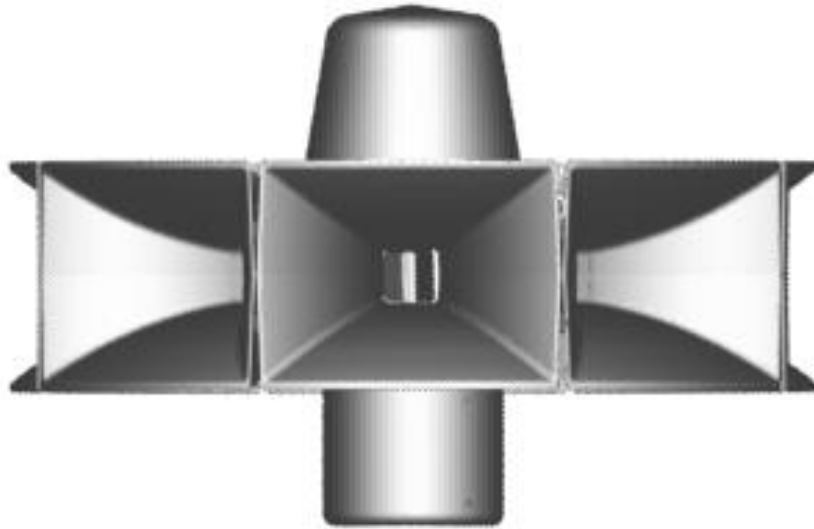

INSTALLATION AND OPERATING INSTRUCTIONS

Copyright 2007 Federal Signal Corporation

IMPORTANT NOTICE

Federal Signal reserves the right to make changes to devices and specifications detailed in the manual at any time in order to improve reliability, function or design. The information in this book has been carefully checked and is believed to be accurate; however, no responsibility is assumed for any inaccuracies.

SAFETY NOTICES

People's lives depend on your selection of suitable equipment and installation sites and your safe installation, service, and operation of our products. Federal Signal recommends the following publications from the Federal Emergency Management Agency for assistance with planning an outdoor warning system: 1. The "Outdoor Warning Guide" (CPG 1-17), 2. "Civil Preparedness, Principles of Warning" (CPG 1-14), 3. FEMA-REP-1, Appendix 3 (Nuclear Plant Guideline), and 4. FEMA-REP-10 (Nuclear Plant Guideline). Contact Federal Warning System's Customer Care Center at: <http://www.federalwarningsystems.com> or 1-800-524-3021 for further information about these publications.

It is important to read, understand and follow all instructions shipped with this product. In addition, listed below are some other important safety instructions and precautions you should follow.

PLANNING

- If suitable warning equipment is not selected, the installation site for the siren is not selected properly or the siren is not installed properly, it may not produce the intended optimum audible warning. Follow Federal Emergency Management Agency (FEMA) recommendations.
- If sirens are not activated in a timely manner when an emergency condition exists, they cannot provide the intended audible warning. It is imperative that knowledgeable people, who are provided with the necessary information, are available at all times to authorize the activation of the sirens.
- When sirens are used out of doors, people indoors may not be able to hear the warning signals. Separate warning devices or procedures may be needed to effectively warn people indoors.
- The sound output of sirens is capable of causing permanent hearing damage. To prevent excessive exposure, carefully plan siren placement, post warnings, and restrict access to areas near sirens.
- Activating the sirens may not result in people taking the desired actions if those to be warned are not properly trained about the meaning of siren sounds. Siren users should follow FEMA recommendations and instruct those to be warned of correct actions to be taken.
- A siren that doesn't work won't provide any warning. After installation, service, or maintenance, test the siren system to confirm that it is operating properly. Test the system regularly to confirm that it will be operational in an emergency.
- If future service and operating personnel do not have these instructions to refer to, the siren system may not provide the intended audible warning and service personnel may be exposed to death, permanent hearing loss, or other bodily injury. File these instructions in a safe place and refer to them periodically. Give a copy of these instructions to new recruits and trainees. Also, give a copy to anyone who is going to service or repair the siren.

SAFETY NOTICES

People's lives depend on your safe installation, service and operation of our products. It is important to read, understand and follow all instructions shipped with this product. In addition, listed below are some other important safety instructions and precautions you should follow:

INSTALLATION & SERVICE

- Electrocutation or severe personal injury can occur when performing various installation and service functions such as making electrical connections, drilling holes, or lifting equipment. Therefore experienced electricians in accordance with national, state and any other electrical codes having jurisdiction should perform installation. All work should be performed under the direction of the installation or service crew safety foreman.
- The sound output of sirens is capable of causing permanent hearing damage. To prevent excessive exposure, carefully plan siren placement, post warnings and restrict access to areas near the sirens. Sirens may be operated from remote control points. Whenever possible, disconnect all siren power including batteries before working near the siren.
- After installation or service, test the siren system to confirm that it is operating properly. Test the system regularly to confirm that it will be operational in an emergency.
- If future service personnel do not have these warnings and all other instructions shipped with the equipment to refer to, the siren system may not provide the intended audible warning and service personnel may be exposed to death, permanent hearing loss, or other bodily injury. File these instructions in a safe place and refer to them periodically. Give a copy of these instructions to new recruits and trainees. Also, give a copy to anyone who is going to service or repair the sirens. For additional copies, call the Federal Warning Systems Customer Care Center at 800-524-3021 or write to them at 2645 Federal Signal Drive, University Park, IL 60466.

OPERATION

- Failure to understand the capabilities and limitations of your siren system could result in permanent hearing loss, other serious injuries or death to persons too close to the sirens when you activate them or to those you need to warn. Carefully read and thoroughly understand all safety notices in this manual and all operations-related-items in all instruction manuals shipped with equipment. Thoroughly discuss all contingency plans with those responsible for warning people in your community, company, or jurisdiction.

Limited Warranty

*The Signal Division, **Federal Signal Corporation**, warrants each new product to be free from defects in material and workmanship, under normal use and service, for a period of two years on parts replacement and bench labor (one year for Informer, EAS, and Federal software products) from the date of delivery to the first user-purchaser. Federal Warning Systems warrants every 2001 and Eclipse series Siren (Top of pole only) to be free from defects in material, per our standard warranty, under normal use and service for a period of five years on parts replacement.*

During this warranty period, the obligation of Federal is limited to repairing or replacing, as Federal may elect, any part or parts of such product which after examination by Federal discloses to be defective in material and/or workmanship.

Federal will provide warranty for any unit which is delivered, transported prepaid, to the Federal factory or designated authorized warranty service center for examination and such examination reveals a defect in material and/or workmanship.

This warranty does not cover travel expenses, the cost of specialized equipment for gaining access to the product, or labor charges for removal and re-installation of the product. The Federal Signal Corporation warranty shall not apply to components or accessories that have a separate warranty by the original manufacturer, such as, but not limited to, batteries.

This warranty does not extend to any unit which has been subjected to abuse, misuse, improper installation or which has been inadequately maintained, nor to units which have problems related to service or modification at any facility other than Federal factory or authorized warranty service centers. Moreover, Federal shall have no liability with respect to defects arising in Products through any cause other than ordinary use (such as, for example, accident, fire, lightning, water damage, or other remaining acts of God).

THERE ARE NO OTHER WARRANTIES, EXPRESSED OR IMPLIED, INCLUDING BUT NOT LIMITED TO, ANY IMPLIED WARRANTIES OF MERCHANTABILITY OR FITNESS FOR A PARTICULAR PURPOSE. IN NO EVENT SHALL FEDERAL BE LIABLE FOR ANY LOSS OF PROFITS OR ANY INDIRECT OR CONSEQUENTIAL DAMAGES ARISING OUT OF ANY SUCH DEFECT IN MATERIAL WORKMANSHIP.



FEDERAL SIGNAL

Federal Warning Systems

2645 Federal Signal Drive, University Park, IL 60466

Phone: (800) 524-3021 Fax: (708) 534-4865

Website: <http://www.federalwarningsystems.com>

WARNING

Read and understand the information contained in this manual before attempting to install or service the siren.

Pay careful attention to the following notices located on the equipment.

NOTICES – EXTERNALLY PLACED.



291184A

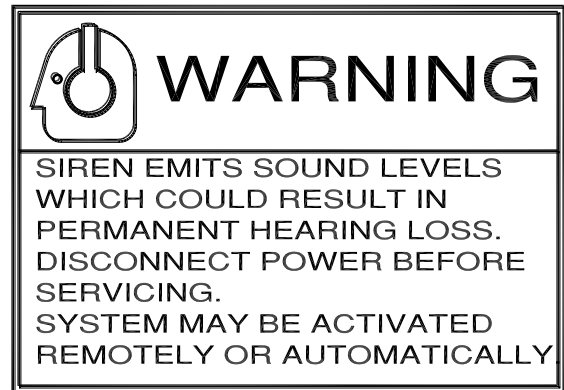

TABLE OF CONTENTS

Section	Page
TABLE OF CONTENTS	vi
TABLE OF FIGURES	vi
SECTION I - CHARACTERISTICS	1
1-1. SCOPE OF THIS MANUAL	1
1-2. GENERAL	1
1-3. SIREN DESCRIPTION	1
1-4. SIGNAL DESCRIPTION	1
SECTION II - SPECIFICATIONS	2
SECTION III - INSTALLATION	3
3-1. SIREN LOCATION	3
3-2. SIREN INSTALLATION	4
3-3. PRE-OPERATION CHECKOUT AND MAINTENANCE PROCEDURE	11
SECTION IV - SERVICE	12
4-1. GENERAL INFORMATION	12

TABLE OF FIGURES

Figure	Page
Figure 1-1. Model ECLIPSE ⁸	1
Figure 1-2. Signal Characteristics	1
Figure 3-1. Siren Leg Assembly	5
Figure 3-2. Typical Pole-mounted Installation	6
Figure 3-3. Conduit Connection Detail	7
Figure 3-4. Typical Surface-mounted Siren Installation	9
Figure 3-5. Weight Distribution Mat Construction	10
Figure 4-1 Eclipse8 Parts List	13
Figure 4-2 EclipseNH Parts List	14

SECTION I - CHARACTERISTICS

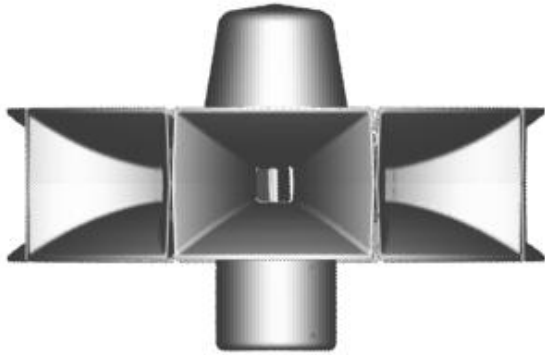

Figure 1-1. Model ECLIPSE⁸

1-1. SCOPE OF THIS MANUAL.

This service manual describes the characteristics, specifications, installation, theory of operation, and service and maintenance of the Federal Signal ECLIPSE series sirens.

1-2. GENERAL.

Federal's ECLIPSE siren (Figure 1-1) is an electro-mechanical omni-directional, DC powered siren that is capable of producing high intensity warning signals over a large area. A highly efficient design enables the siren to produce a high sound level, while making moderate demands on the power source.

1-3. SIREN DESCRIPTION.

The ECLIPSE8 siren is a single tone siren capable of producing a 115 dB sound level at 100 feet for a minimum of 15 minutes, when using the 2001DCB Control Unit/Battery Box with fully charged, standard, deep-cycle, marine batteries. 30-minute duty cycle operation is available with a 2001TRB option. This option supplies DC current directly to the siren from a 208, 220 or 240VAC line.

A single DC motor is used to produce the sound energy. The motor is attached to a stator with a rotor mounted on the motor shaft inside the stator. The rotor and stator each contain one row of ports. As the motor rotates the rotor, air is drawn into the rotor and passes through the rotor and stator ports in pulses. These pulses are produced when the rotor alternately opens and closes the stator ports. The pulses of air produce sound at a frequency (pitch) that is dependent upon the rotational speed of the motor and the number of ports in the rotor-stator combination.

1-4. SIGNAL DESCRIPTION.

The ECLIPSE sirens are capable of producing a steady signal and a wailing signal. The steady signal is frequently used as a Civil Defense "Alert" signal. The wailing signal is often used as a Civil Defense "Attack" signal. Any of the signals are capable of being used for any desired application. These signals are shown graphically in Figure 1-2.

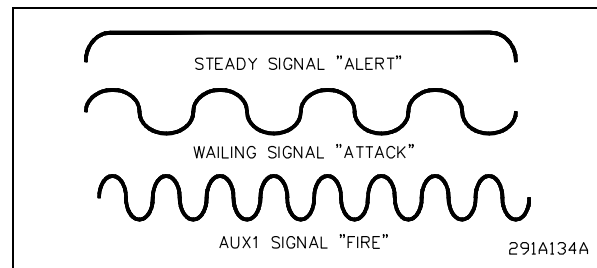

Figure 1-2. Signal Characteristics.

SECTION II - SPECIFICATIONS

Power Requirements:..... 46 VDC (or full wave
rectified AC) 112 amps (nominal)

Wiring: 2 AWG minimum

Motor Type:..... Series Wound DC 7Hp

Signal Information:

Signal	Frequency Range	Sweep Rate
STEADY	525Hz	N.A.
WAIL	500 – 330 Hz	10 sec.
FAST WAIL	490 – 400 Hz	4 sec.

Signal Duration 3 mininutes (programmable)

ECLIPSE⁸ Sound Output (SPL)..... 115 dBc max. (on axis) at 100' (30.5m)

ECLIPSE^{NH} (no horns) Sound Output..... 107 dBc max. (on axis) at 100' (30.5m)

Eclipse⁸ Dimensions (Height/Diameter) 63" / 46.81" (Including stand)
160cm / 119 cm

Eclipse^{NH} Dimensions (Height/Diameter) 63" / 23.63" (Including stand)
160cm / 60cm

ECLIPSE⁸

Siren Weight 255 pounds (116 kg.)

Shipping Weight..... 380 pounds (173 kg.)

ECLIPSE^{NH}

Siren Weight 175 pounds (80 kg.)

Shipping Weight 300 pounds (136 kg.)

Material Aluminum w/stainless steel hardware

Operating Temperature -30°C to +60°C

SECTION III - INSTALLATION

DANGER

Electrocution or severe personal injury can occur when making electrical connections, drilling holes, or lifting equipment. Therefore, installation should be performed by experienced electricians in accordance with national and local electrical codes.

3-1. SIREN LOCATION.

The information in this section provides guidelines to aid the user in the selection of an installation site that makes the best possible use of the siren.

WARNING

The output level of a ECLIPSE siren is capable of causing permanent hearing damage. To prevent excessive exposure, carefully plan placement of siren and post warnings.

If the siren is being installed as part of a Community Warning system, ALWAYS follow Federal Emergency Management Agency (FEMA) recommendations.

Careful consideration of the factors affecting the propagation of sound from the siren and the response of the human ear to the sound will optimize the ability of the siren to effectively warn the community.

The reduction of signal intensity as the distance from the siren increases and the minimum desired signal level at the fringe of the area to be covered are important considerations when choosing a siren installation site. As the distance from the siren increases, sound level losses accumulate. These losses are a result of weather conditions, the terrain, obstructions in the sound path, the pitch of the sound and the height of the siren.

Optimum sound propagation conditions exist when there are no obstructions in the sound path, the terrain is flat, and the air is calm. Under these conditions, each time the distance from the siren is doubled, the sound level decreases by approximately 10 dB.

Assuming a 10 dB loss per distance doubled and a 70dB minimum sound level, the effective range of the ECLIPSE⁸ siren is approximately 1840 feet and the ECLIPSE^{NH} is 1300 feet.

A loss per distance doubled of 10 dB may be experienced because buildings and other obstructions are frequently present in the sound path. In addition, the atmosphere is rarely calm, and the terrain may not be flat. As a result, a typical loss per distance doubled in residential areas may be 10dB, and as high as 12dB or more in areas having tall buildings or other factors detrimental to sound propagation.

Experience indicates an individual with normal hearing will probably hear a warning signal whose intensity is at least as high as the ambient noise level. But, to ensure adequate warning, the warning signal should be at least 10 dB above ambient.

Experience has also shown that the ambient noise level in industrial districts is typically 90dB. Therefore, for a person to hear a warning signal in an industrial area, the sound level intensity of that signal must be approximately 100dB.

In business districts, an ambient noise level of 80dB is common and in residential areas, 68dB of ambient noise is typical.

Wind speed and direction often affect the propagation of sound from the siren. Consequently, the direction of the prevailing wind should also be a factor to consider when selecting the installation site(s). For example, if the prevailing wind is from the west, it may be desirable to install the siren toward the western edge of the area to be covered.

Other factors to consider before selecting the installation site include the availability of electrical power, the ease of installation and maintenance, the height of surrounding obstructions, and security against vandalism.

3-2. SIREN INSTALLATION.

A. General.

Most siren installations are one of two types: Pole Mount or Flat Surface Mount. These two configurations make it possible to install a siren in almost any situation. If the installations in this paragraph are not suitable, modification of one of the configurations may be practical.

WARNING

An Eclipse siren must be installed at least 40 ft. above the ground to ensure sound levels on the ground do not exceed safe levels.

Do not place fingers into any siren openings.

1. Uncrate the siren and remove the nuts that hold the siren on the shipping base. Lift the siren approximately 3-1/2 feet with a crane or hoist using the two eyehooks on the siren.
2. Install the siren legs to the siren using the four 3/8"-16 bolts and lockwashers.

B. Pole Mounting.

A typical siren pole-mounted installation is shown in figure 3-2. The siren is mounted on a Class 2 utility pole at least 40 feet above the ground. It is attached to the pole by means of legs, as shown in figure 3-1.

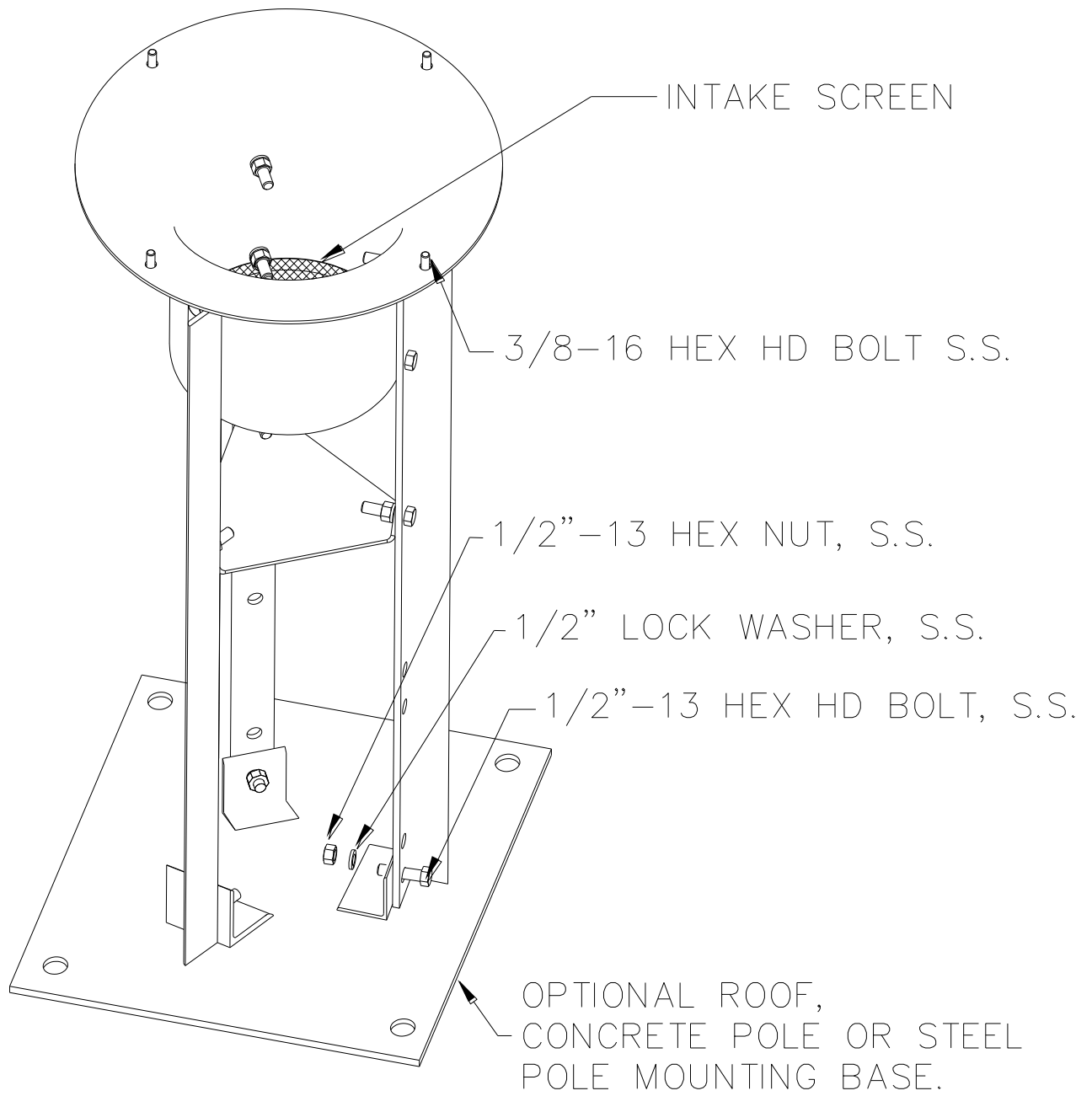

Figure 3-1. Siren Leg Assembly.
(Shown with optional surface mounting plate, Model No. RME)

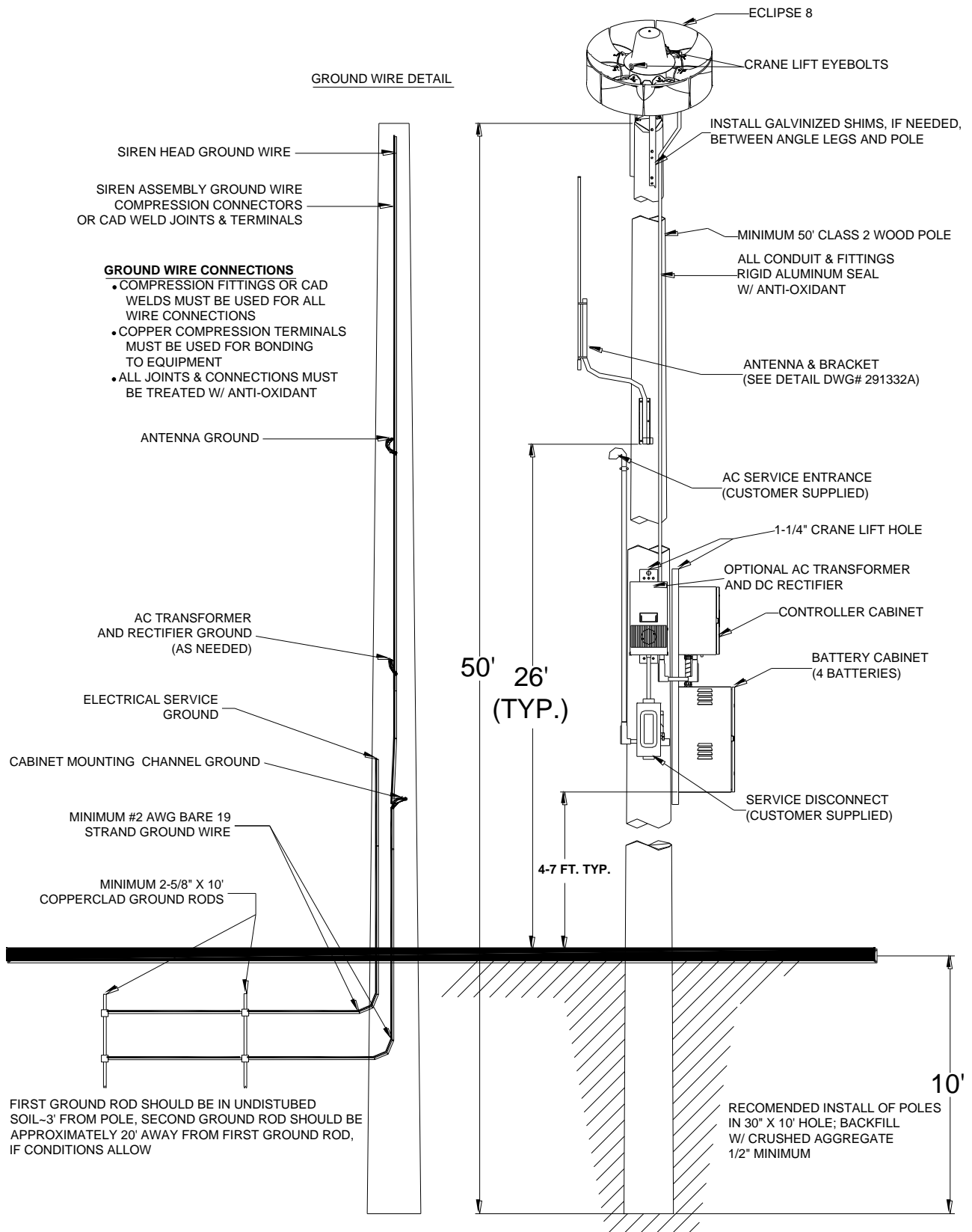

Figure 3-2. Typical Pole-mounted Installation

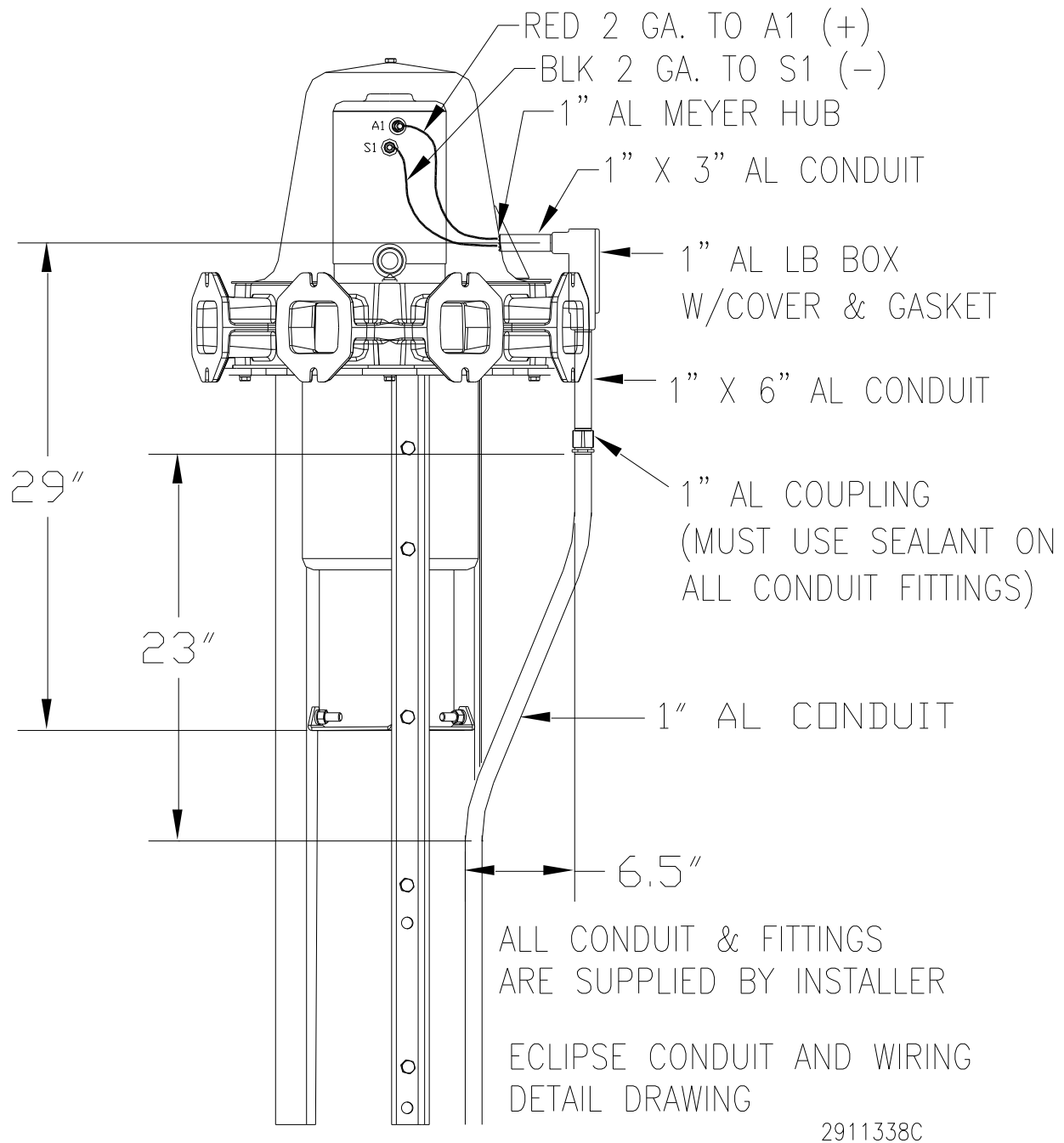

Figure 3-3. Conduit Connection and Wiring Detail

WARNING

The lifting eyebolts do NOT have sufficient strength to support the combined weight of the siren and a utility pole. Therefore, do NOT attempt to erect the pole and siren together using the bracket as a lifting point.

Using the 3 feet long angle iron legs, the siren is mounted on the Class 2 utility pole as follows:

1. Erect the utility pole in accordance with accepted practices. Be sure the pole extends at least 40 feet above the ground (refer to WARNING above).
2. Raise the siren to the necessary height, and lower it over the pole.
3. Adjust the legs and insert shims, if necessary, between the siren legs and pole. Bolt the siren to the pole using two 5/8" lag bolts, at least four inches long for each leg. Tighten all bolts.
4. Install the siren grounding as shown in figure 3-2.
5. Refer to figure 3-3 for running conduit to the siren and follow the instructions provided with the siren controller for making electrical connections – omitting any references to rotation.

C. Flat Surface Mount.

Note: A qualified Professional Engineer should approve mounting locations, materials and methods prior to installation.

A model RME mounting plate is required for mounting on flat surfaces such as a building or top plate of a steel or concrete pole. This installation configuration is practical for buildings that have a flat roof. The siren can be anchored directly to the roof, on a platform as shown in figure 3-4, or on a weight distribution mat like the one shown in figure 3-5.

A mat is required when the siren mounting surface is unable to support at least 280 pounds (127kg.) over a 1.5 square foot area. The mat shown in figure 3-5 distributes the siren weight over an 8 square foot area. When installing the siren on a flat roof, be sure that it clears the parapets or other obstructions by at least ten feet.

To install a ECLIPSE on a flat roof or other flat surface, proceed as follows:

1. If required, construct a platform for mounting the siren, which must be capable of supporting at least 300 lbs. (660kg.) as well as withstanding a siren wind load of 110 mph. The platform must also be capable of distributing its own weight plus the siren to a value that is safe for the mounting surface. Platform design and construction details are left to the installer. Locate the platform at the siren installation site. Using suitable hardware (not supplied), anchor the platform to the mounting surface.

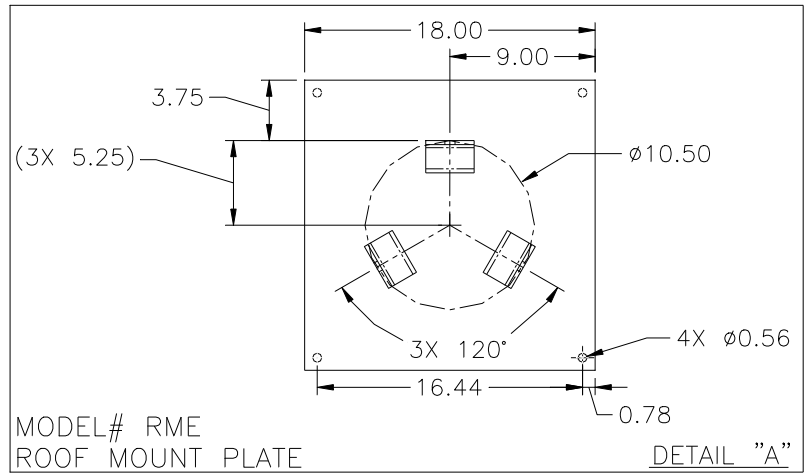
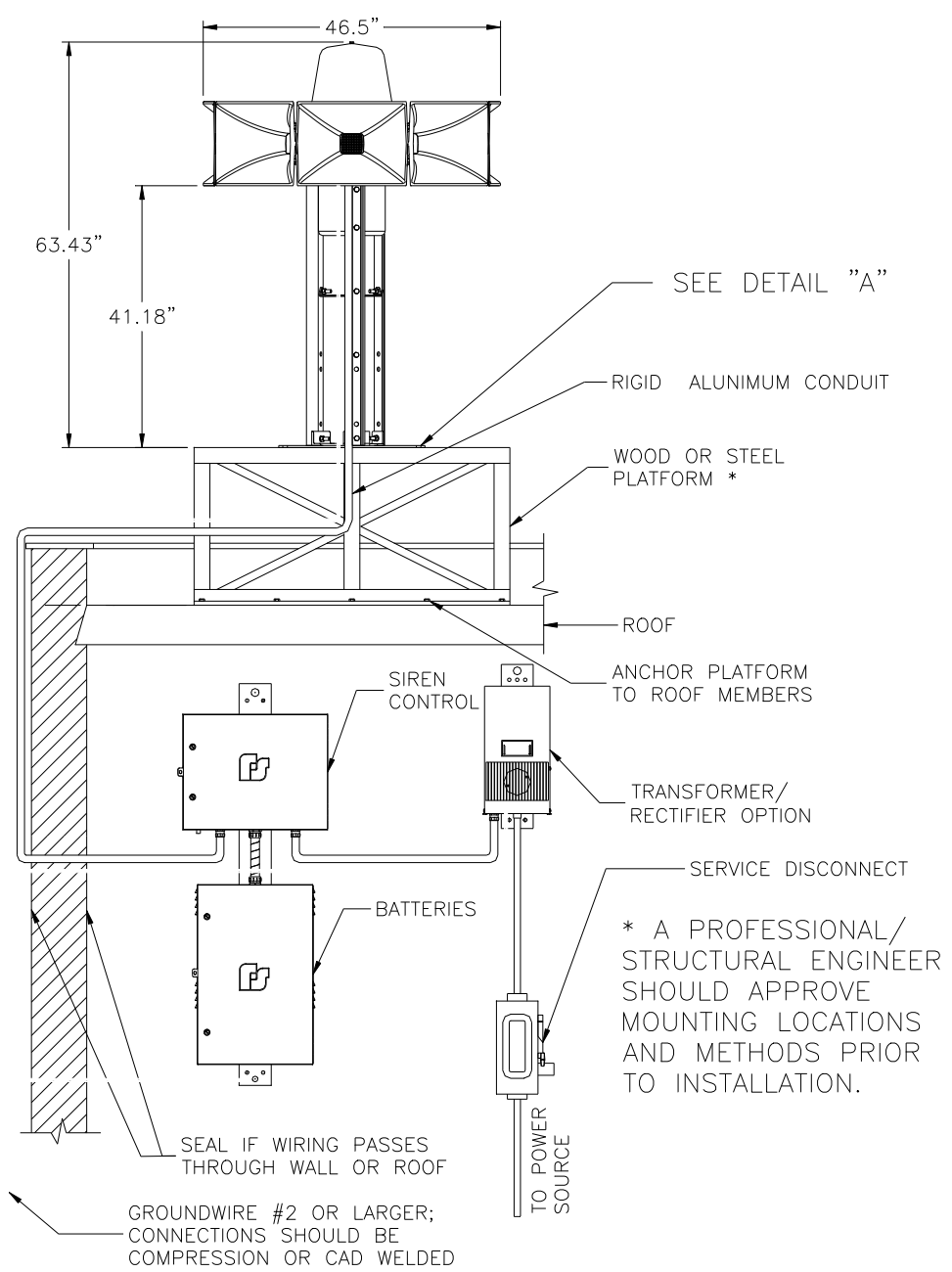

Figure 3-4. Typical Surface-mounted Siren Installation

WARNING

The siren's lifting eyebolts do not have sufficient strength to support the combined weight of the siren and a mounting platform. Therefore, do NOT lift the siren and platform together using the siren's eyebolts as the lifting points.

2. Hoist the siren to the installation site using the two eyebolts as a lifting point (refer to WARNING above).
3. Anchor the siren to the mounting surface with 1/2" lag bolts or nuts and bolts, as appropriate through the mounting holes (one in each corner) in the siren base plate (see figure 3-4, detail A). If the siren is mounted directly on a roof, (without a platform or weight distribution mat) be sure to install waterproof joints at the points where the mounting bolts pass through the roof so that water does not enter the building.
4. Refer to figure 3-3 for running conduit to the siren and follow the instructions provided with the siren controller for making electrical connections – omitting any references to rotation.

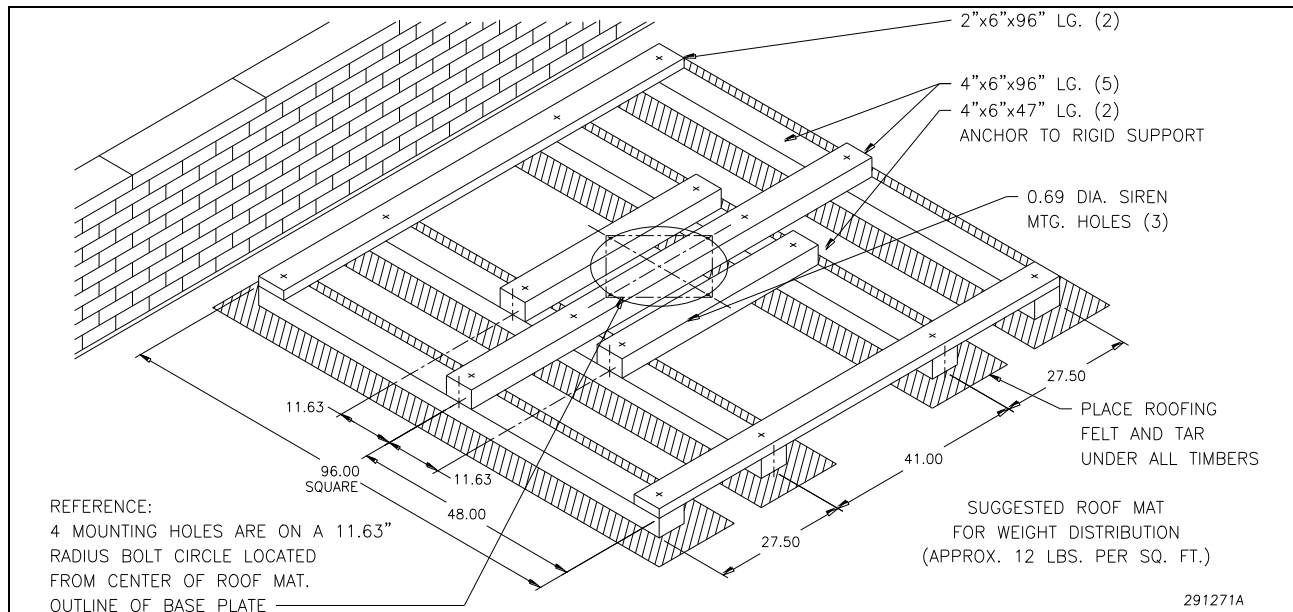

Figure 3-5. Weight Distribution Mat Construction

3-3. PRE-OPERATION CHECKOUT AND MAINTENANCE PROCEDURE

After the siren has been completely installed, perform the following checks before putting the siren into service. This procedure is also recommended as a maintenance procedure.

WARNING

The output sound level of a siren is capable of causing severe hearing discomfort or permanent hearing damage. Therefore, ALWAYS wear hearing protection when performing tests or maintenance on the siren.

- A. Make sure that all air intakes and sound outlets are not obstructed.
- B. Make sure all connections in the Control Unit/Battery Box (if applicable) are correct and properly tightened.
- C. Ensure the mounting structure is secure and all siren hardware properly attached and secure.
- D. Ensure all people and animals are at least 40' away from the siren in every direction to avoid hearing damage.
- E. Activate a siren function at the control panel and check for proper sound output.
- F. After the installation is complete and it has been established that the siren is operating properly, Federal recommends that all control devices be padlocked to discourage tampering and vandalism.
- G. Test the ECLIPSE siren for proper operation at least once a month. A daily test at noon, curfew, or other selected time is preferred. This not only enhances the usefulness of the siren, but instills public confidence in the reliability of the warning system.
- H. In order to minimize the possibility of siren failure, annual inspection is desirable. If applicable, battery replacement should be performed approximately every 3-5 years. This schedule is only a suggested guideline. It may be necessary to vary the schedule if the siren is used frequently or if it is used in an extreme climate.

SECTION IV - SERVICE

4-1. GENERAL INFORMATION.

DANGER

Service should be performed by qualified personnel familiar with the siren, associated controls, and power sources being used. The siren has moving parts, high operating currents, and may have explosive gases and corrosive materials that could cause severe personal injury, electrocution, or death. Before servicing or maintaining, ensure that remote activation can not occur and disconnect power to the siren and its controls.

WARNING

The output level of a ECLIPSE siren is capable of causing permanent hearing damage. Therefore, ALWAYS wear hearing protection when performing tests or maintenance on the siren.

Experience has shown that all Federal sirens are highly reliable devices. However, if a siren failure does occur, Federal will provide technical assistance with problems that cannot be handled satisfactorily and promptly locally. If assistance is desired, contact:

FWS Customer Care Center
Signal Division
Federal Signal Corporation
2645 Federal Signal Drive
University Park, Illinois 60466
800-524-3021

Refer to figures 4-1 and 4-2 for a complete siren parts lists.

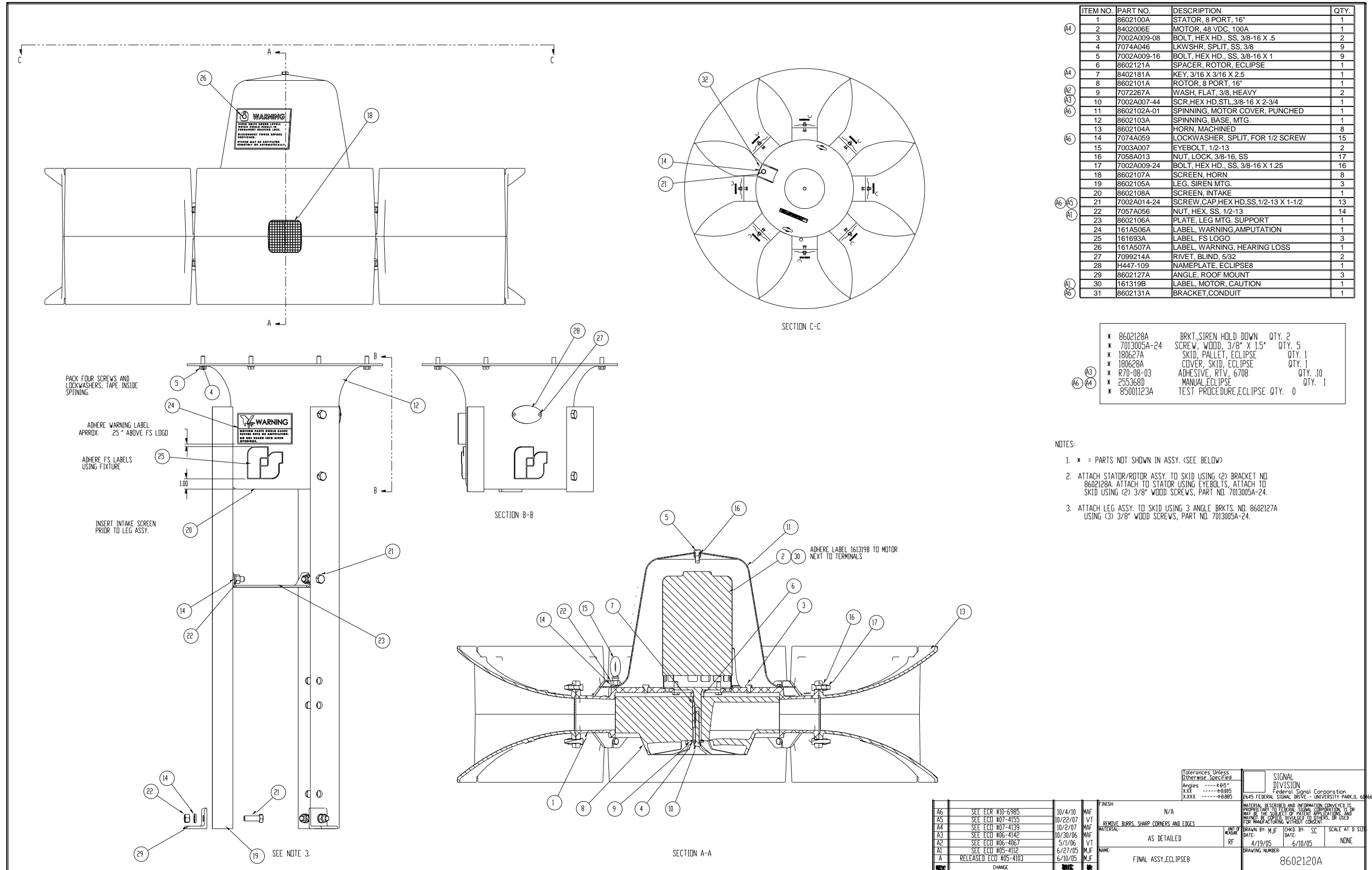

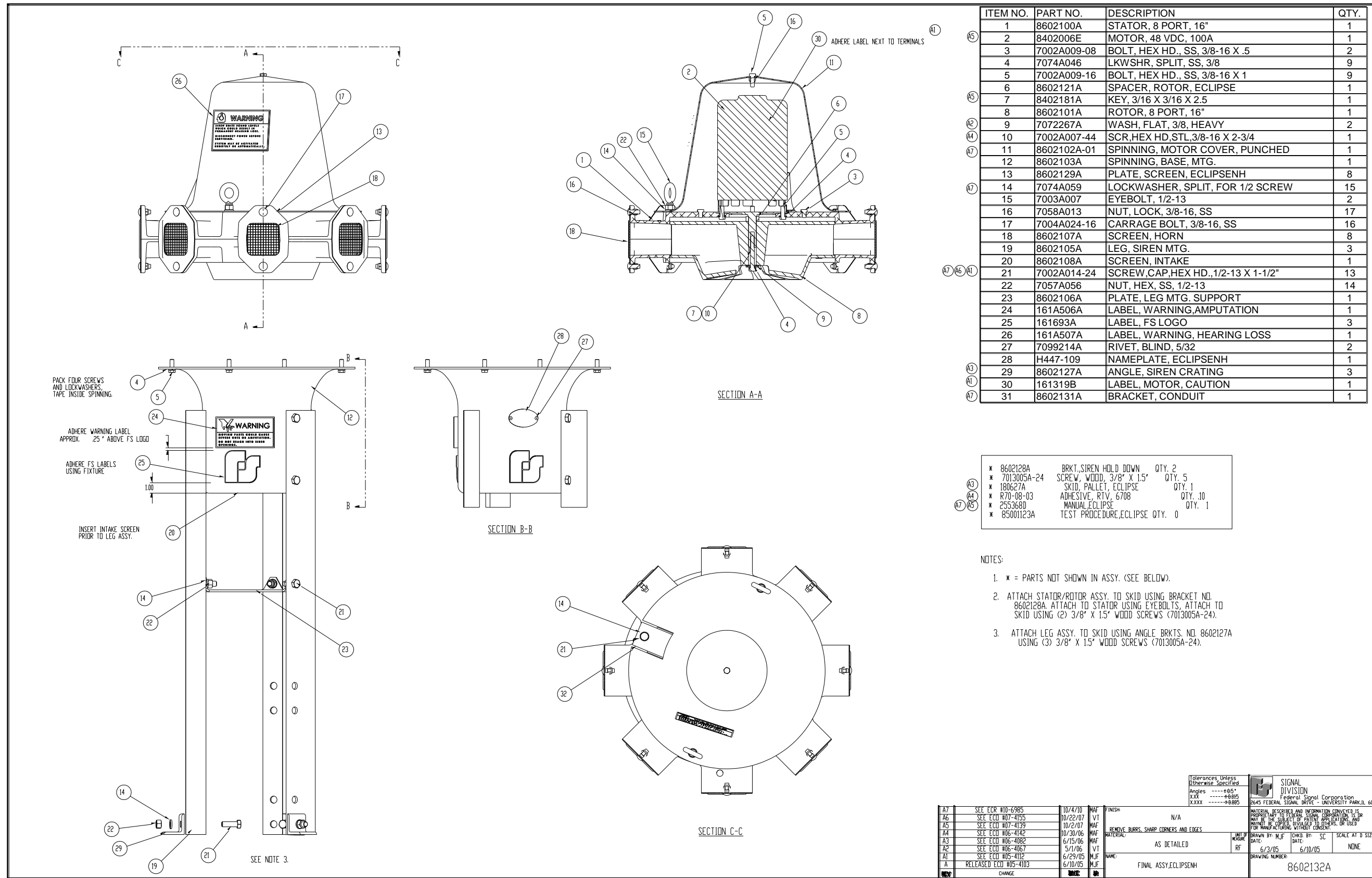

Figure 4-2 EclipseNH Parts List