



## *Elements of a Superior Citizen Alerting System*

*Federal Signal Corporation*

*Published: August 2007*

---

### **Abstract**

Municipalities, School campuses and other organizations are quickly realizing the importance of having Citizen alerting systems. When emergencies ensue, it is of paramount importance that populations can be alerted quickly to be given instructions and updates. This whitepaper discusses several of the most key factors to consider when assessing Citizen alerting systems. Emergency Response and Security leaders have a responsibility to do all that is feasible to keep their populations safe and informed. In order to do this it is important to prepare so that even in the most chaotic or catastrophic incidents, large numbers of individuals on campuses and in communities can be notified immediately.

*This White Paper is for informational purposes only. Federal Signal makes no warranties express, implied or statutory, as to the information presented in this white paper document.*

*Federal Signal may have patents, patent applications, trademarks, copyrights, or other intellectual property rights covering subject matter in this document. Except as expressly provided in any written license agreement from Federal Signal, the furnishing of this document does not give you any license to these patents, trademarks, copyrights, or other intellectual property.*

*If you have comments on this publication or would like additional information from Federal Signal please contact us at [info@federalsignal.com](mailto:info@federalsignal.com)*

*© 2007 Federal Signal Corporation. All rights reserved.*

*The names of actual companies and products mentioned herein may be the trademarks of their respective owners.*

---

# Contents

**Introduction..... 1**

**Getting the Message Out in Time..... 2**

**Reaching Different Device Types Over Various Communication Mediums..... 3**

**Targeting Alerts ..... 4**

**Usability on a Regular Basis ..... 5**

**The Public Safety, Security and Well-being Platform..... 7**

**Citizen Alerting – Customer Experiences ..... 9**

**Summary ..... 10**

**Appendix – Additional Information..... 11**

---

## Introduction

Citizen Alerting is mass alert notification. A Citizen Alerting System (CAS) provides a way for leaders to notify high volumes of individuals quickly. Municipalities require these systems for alerting citizens during emergency and non-emergency events in a timely manner. In addition to municipalities, sites involving large populations (such as College and University campuses) also need this capability to notify promptly.

### The importance of Citizen Alerting

Communications to personnel is essential during times of crisis in mobilizing response teams. Likewise the ability to notify the masses can be equally significant. In order for security authorities to direct activity, give instructions and maintain order in emergency situations, they must have the means to alert the public expeditiously.

### Factors of an Effective Citizen Alerting System

To truly be effective, a CAS must be usable, secure and affordable. It should have the ability to reach people using multiple methods to give alerting capability even during times when some communication mediums may be rendered inaccessible. Although its use should not be limited to emergency situations, systems should be designed with extreme disaster situations in mind.

The following questions should be considered when evaluating a CAS:

- Can it get a message out in time?
- Can the system notify mass numbers of recipients quickly?
- Can the system reach multiple device types and utilize various communications mediums?
- Does the system incorporate redundancy/fault tolerance?
- How cost effective/affordable is the solution?
- Can alerts be sent to targeted subgroups as well as to the entire register or recipients in the system?
- Does the system support individuals providing their own contact data?
- Is the system usable on a regular basis?
- Does the system provide a real-time dashboard and other measurements of success tools to assist with making sure that a message was successfully delivered?
- Does the system incorporate other warning systems including sirens, lights and beacons, and public address systems.

#### Washington Technology News

Chertoff: Interoperability on fast track in cities

All 50 states should aim to have interoperable systems for public safety by the end of 2008, Chertoff said during keynote speech at the National Grants and Training Conference in Washington.

Fostering interoperable communications systems for first responders has been a goal of the Homeland Security Department since Congress created it four years ago. The goal is to allow police and fire departments of multiple jurisdictions to talk to one another in real time in responding to a major incident.

Disparate radio systems prevent that from happening in most communities.

"We have the first generation of equipment," Chertoff said. "We know that what's needed at this point is finishing the governance plans and the documents, and we also know that we need to complete the job of getting the specifications for the next generation of digital equipment out there, so you can complete the process of being able to do your own planning for your next generation of purchases."

The goal is to be able to warn 85 percent of the "listening public" within 10 minutes, he said. The public warning system needs new technologies, he said.

---

## Getting the Message Out in Time

Getting alerts out promptly is of key significance. Obviously, if an alert gets to an individual after a situation has passed or later than a necessary response time window, the message has lost its value. An urgent communication that comes too late, when it no longer applies, can often cause further problems and undue confusion or panic. Speediness of urgent alerts is of particular concern in avoiding damage, injury or even death.

Consider the following three dynamics concerning the speed of mass alerting systems:

1. Procedure/protocol in initiating the alert
2. Number of available outbound channels
3. Speed of the system feeding those outbound channels

It is imperative to have procedures and protocols in place that facilitate initiating alerts to the correct audience as quickly as possible. FS Codespear's solution helps an organization in doing this in various ways. A simple and easy-to-use sending interface allows for easier training of dispatch personnel (on an ongoing basis as staff changes). Additionally, many built-in features such as alert templates, alert Forwarding, and audio creation/attachment capabilities can aid an organization in defining specific courses of action for various situations. Another primary aspect of FS Codespear's software is its remote accessibility. Authorized personnel can initiate an alert from virtually anywhere there is a network or phone connection.



A full-featured alerting system gives leaders the ability to structure courses of action for various situations and accelerate initiation of messages. Customers have options for using their own internal outbound channels for phone dialing, SMS and SMTP alerting. FS Codespear also provides hosting services in which customers can utilize a large hosted network for sending mass alerts.

In addition, there are options for employing hybrid solutions, in which both customer infrastructures along with FS Codespear infrastructure is utilized simultaneously. Hosted dialing services provide customers with access to very large numbers of phone lines without the cost of investing in dialing infrastructure. This gives the customer many alternatives to maximize throughput for getting urgent alerts out to its public.

An alerting system should be capable of utilizing all available outbound channels to deliver an alert to recipients. The scalability of FS Codespear's system affords fully utilizing even extremely large numbers of outward channels, by permitting the use of multiple servers to handle the load. Capacity at the backend (for supplying outbound channels) is increased by the simple addition of low cost, COTS (Commercial off-the-shelf) hardware, without the need to redesign or reconfigure the system.

---

## Reaching Different Device Types Over Various Communication Mediums

Unified messaging – reaching many different device types with a single message is of major significance for a citizen alerting system. The ability for authorized personnel to send one alert and have it hit everything at once allows for much quicker distribution of messages. A system that provides for broadcasting alerts via various communication mediums is imperative for emergency notifications – if you rely on only one communication medium and that infrastructure is unavailable during a particular crisis, your system is rendered useless.

Pairing site redundancy with the ability to contact different device types simultaneously provides an elevated level of resilience to a system and a higher probability that communications will get out even during the most disastrous situations when normal communication systems may be crippled.



FS Codespear is the leader in communication solutions that can touch virtually any device type and work over any medium. Its SmartMsg platform currently has the ability to reach cell phones, pagers, loudspeakers, desktop and laptop computers, landline phones, sat phones, PDAs (PocketPC, Blackberry, etc.) simultaneously. FS Codespear's platform/foundation also provides for rapid development of new interfaces to accommodate new device types or protocols very easily. In addition, SmartMsg also has a full API (application programming interface) that can allow for sending specialized messages to other emergency systems automatically.

### System Redundancy/Fault Tolerance

A superior CAS includes fault tolerance and site redundancy. During crisis, it is quite possible for an entire area to be rendered inaccessible or otherwise useless, due to fires, floods, man-made disasters and so forth. A system incorporating redundancy at a site level facilitates continued alerting in spite of loss of an entire location. Site redundancy is often neglected due to a high (or perceived high) price tag. Understandably, redundancy has to be affordable and justifiable in order for decision makers to consider it.

By providing redundancy at a software level, FS Codespear's solution offers very low cost site back-up (no expensive proprietary hardware necessary). Multiple standard-spec servers can be employed at separate sites, allowing an agency to be adequately prepared for possible disaster situations. This built-in software redundancy is ready for a catastrophe. No server or location need be central to controlling the system - all servers in the system are equal. Therefore, in a multi-site system, any entire location could be lost completely without affecting functionality; the system can still be fully operational. Immediate and automatic failover occurs at both the server and client levels, without the need for any manual intervention. FS Codespear's redundancy-capable software foundation is fully scalable as well, meaning that new sites/servers can be added on later without the need for system redesign nor long configuration or maintenance times for system expansion.

## Targeting Alerts

There will be times when alerts need to reach all recipients designated in a CAS and there will be other times when only sub groups need to be notified. For example, a county may only need to notify residents in a particular radius area after a chemical spill, or a university campus may only need to alert students in a particular building for a security lockdown. An effective CAS allows a message sender to select particular sets of recipients depending on the specific situation.

The SmartMsg GIS console application facilitates sending alerts based on geographical/map data – such as radius of an incident, relationship to gas/water/electrical utilities and pre-defined regions, such as zip codes, city limits, etc. This can prove extremely valuable for many urgent situations in which a very specific set of residents need to be notified immediately because the message is then aimed exclusively at individuals that are affected; time is not wasted on notifying others that are not affected and the message can reach its necessary audience sooner. As well as allowing proper personnel to notify affected recipients quicker, confusion is avoided in sending a notification to individuals that should really not receive the alert in the first place.

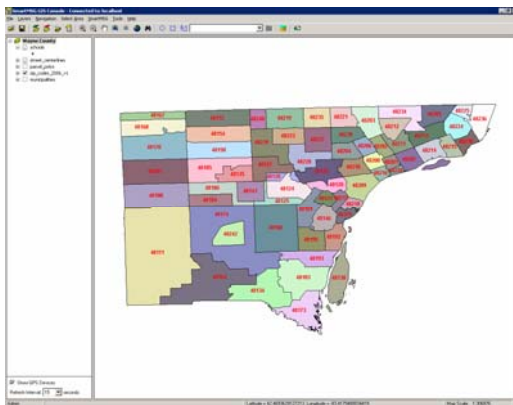

Map data gives one way to target alerts to specific groups of recipients. Additionally, FS Codespear CAS provides for non-geographical grouping of recipients as well. Groups can be preconfigured and ready for sending based on any information pertinent to the particular organization. Examples for educational campuses might include- dormitory buildings, grade levels, extra-curricular team memberships, ... Examples for municipalities could include school attendance (for closings due to weather), subscription type items like particular road closures, community memberships, etc.

### Options for individuals to provide their own contact data

Complete central maintenance of contact data for large volumes of recipients can be next to impossible due to the sizable volume of data and that the data will tend to change often. Individuals may change cell phones, move in/enroll, move/graduate, etc. A good CAS gives multiple options for contact data creation and maintenance. Included in those options should be opportunity for allowing individuals to enter and update their own personal contact information.

FS Codespear provides web interface capability for individuals to register to the system and/or to subscribe to various alert types. This allows recipients to enter their own contact information and to maintain their own data for the alerting system. There are options for administrators to maintain information as well, with the ability to import or refresh information from existing data sources such as student registries, telco company contact lists, and so on. The major concern with CAS data is ensuring its ongoing validity. It is extremely crucial to have correct contact information.

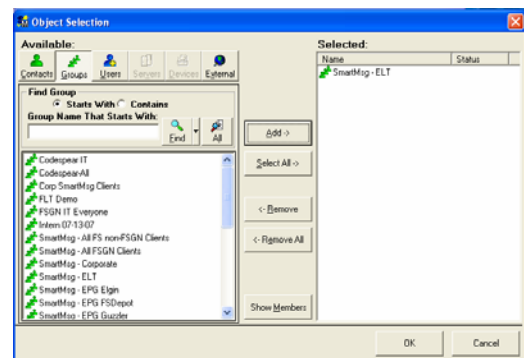

## Usability on a Regular Basis

In general, solutions that are intended for emergency use can be much more effective if used more regularly than merely for very urgent situations. Tools that are exclusively used during crisis situations can often encounter failures when needed most. Consider examples of emergency systems that did not work as expected, in the course of recent urgent events: During the massive Northeast blackout of 2003, there were reports of backup power generators failing at cellular towers, adding to communication disruptions. And, much more devastatingly, during the 2004 Tsunamis, early warning systems did not seem to operate as expected.

Emergency systems should be tested and/or used routinely. This prepares proper personnel to utilize the tools quickly and correctly at a time of crisis when confusion and commotion often ensue. It can be impractical to expect staff to remember processes that are not practiced regularly. In addition, testing or utilizing a system consistently can preemptively reveal any problems that might surround a faulty process or defective component upon which the system may rely.

For example, if a county can use its alerting system to notify of more routine incidents, such as a highway closures and school closings, it can get more for its money by regularly providing a service to its residents. At the same time, since the personnel responsible for using the system utilize it more frequently, they are bound to be more proficient with it.

Employing a user-friendly, simple to use software interface, FS Codespear's SmartMsg solution provides a citizen

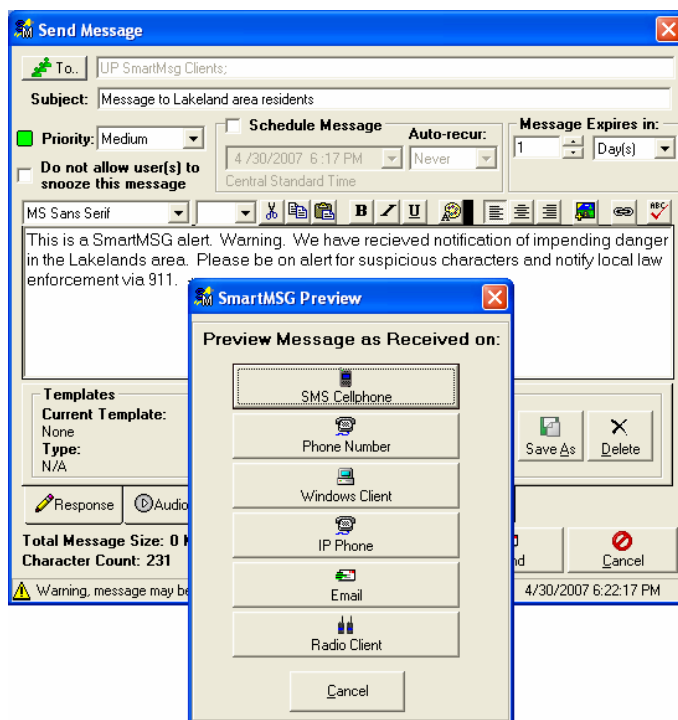

alerting system that can be used frequently; Intensive instruction is not necessary for sending alerts which facilitates more immediate training of new staff. The Alert template functionality affords agencies the ability to have pre-defined alerts ready for various events and situations, for example: Amber alerts, road closures, school closings, etc. Security and user authorization can be configured very specific to a particular agency's needs thus allowing for structuring permissions, for instance: Regular dispatch staff can be granted authority to send more routine alerts, while permissions for sending more urgent elevated priority alerts can be limited to more senior or executive personnel.

### Proprietary hardware can be expensive

Proprietary hardware can be costly for multiple reasons. First of all, as a general rule it is expensive to acquire and expensive to replace. Often times, it is very difficult or impossible to replace or build on over time. In addition, proprietary hardware is not flexible in its

functionality; it is normally only useful for its single specific purpose. Even in cases where an alerting system is used more routinely, it can be difficult to justify large hardware expenditures for proprietary hardware. FS Codespear's alerting system uses standard off-the-shelf hardware. This allows an organization to take advantage of the low cost of stock readily-available hardware and/or to utilize existing hardware investments, such as servers, data lines, and dialing equipment that are already in an organization's possession.

### **Building hosting or dialing infrastructures can also be costly**

In most cases, an organization needs access to great numbers of phone lines and/or hefty outbound data channels for reaching its population, but not on such a routine basis as to justify the expenditure to build out these systems from scratch.

Developing server sites, data lines and dialing infrastructure from the ground up can prove costly. FS Codespear offers many hosted alternatives to customers including: access to many thousands of phone lines as needed and 24-7 server hosting services. This can allow the customer to take advantage of already-existing data and dialing infrastructure systems and to send out alerts very rapidly to large numbers of recipients, while also keeping expenditures lower.



### **Dialing Costs**

One of the key aspects affecting CAS costs is the rate for ongoing dialing. Per-minute/per-call costing should be a chief factor taken into account when evaluating the overall expenditures for a system. There are two ways in which a FS Codespear customer is able to save on continuing dialing expenses for a CAS. First of all there is an option to utilize the customer's own dialing infrastructure (either in total or for partial dialing needs).



This is a good option for some agencies to economize as there are no "per" charges from the CAS provider for voice calls when handled through a customer's own hardware infrastructure. Secondly, customers that utilize hosted dialing services (whether for their entire dialing needs or as a supplement to their own dialing structure), are able to take advantage of FS Codespear's major telco provider relationships which allow for very low, extremely competitive per minute/per call dialing fees.

### **Why having multiple paths to send out messages is important**

While using the emergency alerting systems for daily non-emergency communications is important so is the strategy to have multiple paths and solutions for the distribution of alerting messages. With the FS Codespear platform customers have the opportunity to receive a message on any device, in any location, at anytime. This creates a fully redundant real time interoperable communications path to deliver messages to the intended party.

Next we will discuss our interoperable communications platform strategy for the public safety, security, and well-being industry.

## The Public Safety, Security and Well-being Platform

Today, Federal Signal provides hundreds of products and integrated solutions that help enhance public safety, security and well-being around the world. From Fire Rescue to all-hazard warning systems, to the latest environmental solutions, Federal Signal is uniquely positioned to help municipal and industrial leaders protect people, property, and the environment. As Federal Signal continues to innovate and invest in our core products and services, we are enhancing those solutions with wireless broadband technologies for public safety along with interoperable communications solutions that are used by commercial organizations, municipalities, and other government entities around the world. These solutions are being brought together via an interoperable communications platform that is referred to as the Federal Signal Platform ('platform').

The platform will help establish a basis for customers to converge the best features of their current communications investments at the same time that they can confidently invest in future integrated solutions. The platform is interoperable by design, provided by Federal Signal and enabled by our world-class partners. This includes solutions such as facility management systems, parking and revenue management systems, license plate recognition, 911-emergency operations centers, dispatch, records management, integrated on-board vehicle and maintenance, intelligent warning and notification, and battlefield management. Federal Signal's vision is to provide a real-time intelligent analytics platform that helps enable public safety, security and well-being. The FS Codespear platform represents a huge breakthrough in terms of organizational productivity, data integration and solution platform capabilities. By employing many of the principles and technologies described earlier, the platform delivers out-of-the-box solutions that enable end-users to leverage business data and participate in business processes through a number of easy-to-use interfaces.

**Enterprise Modules** include those solutions that customers can buy that automatically plug into the platform for interoperable communications and data sharing. The key features include:

- Plug into the platform
- Can be developed by Federal Signal (eg. SmartMsg, ScenarioMgr, Radio Interoperability, Siren Commander, Campus Alerting)
- Can be developed by partners or customers

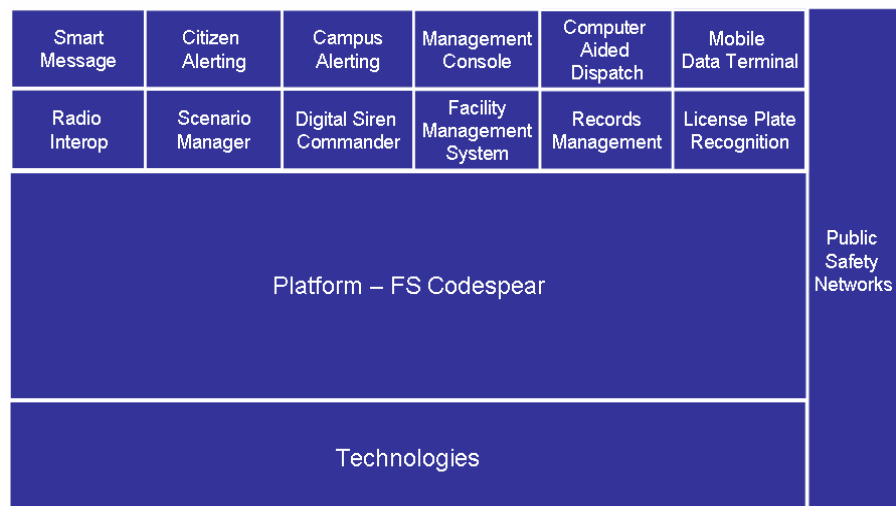

**The Interoperable Industry Platform** is the routing and messaging software layer that enables anytime, anyplace and any device connectivity via a common defined interface. The interface is in the Applications Programming Interface (API) family and enables connectivity to Federal Signal products and solutions as well as industry

solutions from other providers. This includes the following: vehicular, structural, notification, control, monitoring and people interface units in addition to the radio and sensor box interface units. The key features include:

- Interface units that are made up of 1 to many Applications Programming Interfaces (API's)
- API's are modular and standard across the platform to provide maximum performance and an embedded code version or chipset execution

**Technology Competencies** are key enablers of the platform and include sensors, tags, and detectors such as GPS, VoIP, Wireless/Cellular, Biometrics, Geo-Fencing, 3D, RFID, WAVE, Voice recognition, and web services along with Industry Standards (eg. CAP, RS232, IP, SAPI).

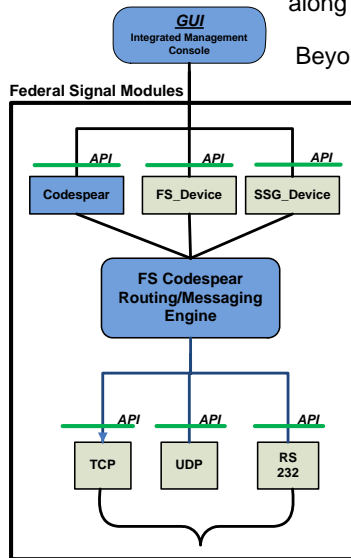

Beyond providing rich out-of-the-box solutions and a critical mass of platform

technologies, the Federal Signal FS Codespear platform provides an infrastructure on which enterprises can build, deploy and host user-driven applications. By building on top of the platform, enterprises can take advantage of the services and characteristics of the latest technology innovation.



Both broadcast of urgent alert notifications and communications interoperability are essential for public safety. Today there is an abundance of communication devices available and modern technology affords a wide array of devices to fit various communication needs. The platform has numerous capabilities to help leverage these devices effectively to facilitate public safety needs.

No application or platform is an island. Even though many are still created with an internal focus, the reality is that connecting applications together has become the norm. Yet connecting software for public safety, security, and well-being solutions is about more than just exchanging bytes. As organizations move toward a service-oriented architecture (SOA), the real goal — creating processes that unite separate applications into a coherent whole across application platform boundaries — comes within reach.

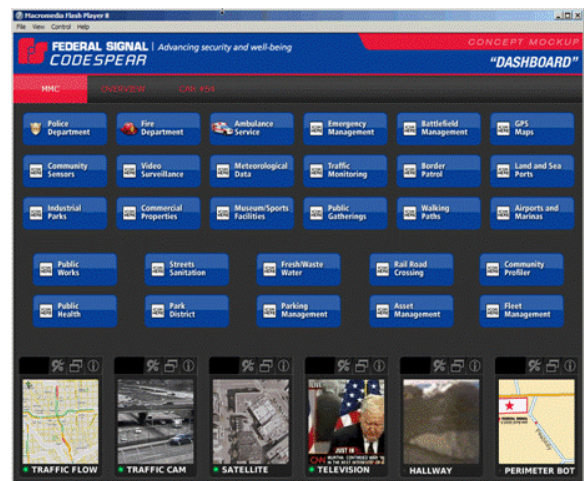
Ease of implementation and the ability to customize for your unique needs are key features of the Federal Signal platform. The platform will work with your existing systems AND is flexible enough to adapt to tomorrow's advanced technology environment. Many customers are up and running on the platform in as little as a few weeks. The Federal Signal platform offers hosted and hosting options that enable you to decide how you would like to sequence your emergency response and fail-over systems structure. Support of the UASI test scenario requirements and NIMS guidelines from the Department of Homeland Security form the basis for the feature architecture of the platform. Non-technical staff can “program” platform features such as Scenario Manager, which offers individual customers the ability to create customized emergency response and alerting systems without actual custom software development.



## Citizen Alerting – Customer Experiences

		
<b>Citizen Alerting in Wayne County Michigan</b>	<b>Campus Safety at University of Texas at Austin</b>	<b>Omaha UASI Region deploys urgent alert notification</b>
<p>Wayne County, Michigan recently implemented Federal Signal's FS Codespear software platform to establish direct emergency communications to the county's residents, businesses and public safety agencies. The software, currently being used to establish complete interoperable communications and public safety alert notifications, will enhance the traditional methods of television and radio for public alert notifications. Wayne County, the eighth largest county in the nation with more than 2.2 million residents across 43 communities, has deployed FS Codespear's software to provide interoperable communications to the county's homeland security, emergency management and public safety departments.</p> <p>"FS Codespear not only allows public safety officials in our communities to communicate and collaborate in a way never before possible, but it allows us to better protect the public during emergencies," said Wayne County Executive, Robert Ficano. "Before choosing FS Codespear, 43 separate transactions were required to get a single message out in each of our communities. Now it's one click of the mouse. While you can't put a dollar amount on saving lives, the FS Codespear system is the most comprehensive and cost effective we've seen." In the event of a natural disaster, terrorist attack, or other emergency crisis incident, Wayne County residents will be notified via home and office telephones, mobile phones, text-based devices or PC's.</p>	<p>The University of Texas at Austin is a leading university with a mind on protecting its campus. Recently the university implemented the new Federal Signal CampusAlert solution. This system will help protect and warn more than 70,000 students, faculty and staff that are a part of the campus community that spans over a 350 acre area. This new CampusAlert™ system is made up of four directional array speakers (DSA), which have the capability of producing tone-alerts and voice announcements that are strategically placed to help insure coverage of the whole campus.</p> <p>The DSA's are controlled by the Federal Signal UltraVoice electronic siren controllers that offer unparalleled voice reproduction of live or recorded voice messages. The campus police will have control of the Campus Alert system via the Federal Commander digital software and the interoperable communications platform from Federal Signal. The solution offers secure activation and status monitoring of the siren system from a central computer.</p> <p>The University of Texas at Austin system will be used to notify the campus community, neighboring residences and businesses in the event of unsafe conditions outside do to weather or environmental hazards and if there is an armed individual on campus.</p> <p>In order to educate the campus and surrounding community the system is tested the first Wednesday of each month at 10:50 a.m. Central time.</p>	<p>The Omaha Tri-County Urban Area Security Initiative (UASI) Region, composed of the City of Omaha, Douglas County, Sarpy County and Washington County have deployed the FS Codespear interoperable industry platform to enhance emergency management, planning and response within each respective agency's emergency management operations.</p> <p>In addition to the implementation of FS Codespear's core SmartMsg 5.2 alert notification application, the Omaha UASI Region has also licensed the FS Codespear Scenario Manager module, which is an integrated incident planning and execution tool that enables the definition of tiered response plans, based on incident events and their dependencies with other tasks, Resources, or Procedures.</p> <p>This application module sets a new paradigm in achieving National Incident Management System (NIMS) compliance and electronic execution of response plans and mutual aid requests.</p> <p>The Omaha UASI region that is implementing the solution includes the tri-county area of Douglas, Sarpy and Washington counties consisting of a population of over 650,000 citizens spanning more than 900 square miles. After considerable planning and competitive evaluation, FS Codespear was awarded the regional contract. In addition, FS Codespear supported the Omaha UASI Region in October 2006.</p>

## **Summary**

The importance of alerting masses during a crisis situation cannot be reasonably refuted. When emergency response leaders are responsible for keeping order and reducing chance of damage, injury and death, it is imperative that those leaders have the proper tools to quickly notify their populations with instructions. It is critical that security and emergency response authorities implement systems for extreme incidents preemptively rather than waiting until disaster strikes and damage is incurred. In evaluating a CAS (Citizen Alerting System) it is important that these officials consider cost effectiveness, usability, unified messaging (reaching many device types with a single message), system redundancy and fault tolerance, and how quickly an urgent alert can be delivered to all individuals. They have an obligation to put quality alerting systems in place, create sufficient procedures and train their personnel accordingly. Fortunately, there is a proven, superior CAS solution available and in use today, through the Federal Signal Interoperable Communications platform and FS Codespear, which allows for notifying sizable citizenry quickly, efficiently and affordably.

---

## Appendix – Additional Information

Federal Signal is a global industry leader that has made significant investments in the products, solutions, and technologies to help enable a robust platform for Citizen Alerting. The platform helps ensure that residents can live and work in a secure and healthy environment, which is one of the highest priorities today's municipal leaders face. Local governments around the world share the need to protect people, property and the environment during natural and manmade disasters. When the unexpected happens, first responders need to minimize and manage impact in their communities. Federal Signal offers the platform, tools and expertise to help prevent, detect and respond to public safety and security events every day. Our unique technology, leading products and engineering expertise deliver the intelligence, interoperability and functionality you need. With an unmatched capability in public safety, security and well-being, Federal Signal is the partner that you can rely on to meet the mission-critical demands of an uncertain world.

### Additional information can be found with the following links:

- Wayne County and Federal Signal FS Codespear
  - [http://Codespear.com/MichiganDeploysStateWideInteroperableCommunicationsandAlertingSolutionFromCodespear\\_4698.aspx](http://Codespear.com/MichiganDeploysStateWideInteroperableCommunicationsandAlertingSolutionFromCodespear_4698.aspx)
- 2007 State of the County (Wayne County) address by Robert Ficano
  - <http://www.waynecounty.com/ceo/state.asp>
- University of Texas at Austin
  - <http://federalsignal.com/pdf/pressRelease/2007%205%201%20University%20of%20Texas-Austin%20FINAL.pdf>
- Omaha UASI Region deploys urgent alert notification and scenario management solution
  - [http://federalsignal.com/News\\_2620.asp](http://federalsignal.com/News_2620.asp)

### Public Safety, Security, and Well-being Solutions from Federal Signal:

- FS Codespear Interoperable Communications Platform
  - <http://www.Codespear.com>
- Campus Alerting Solutions
  - <http://www.federalwarningsystems.com/products.php?prodid=45>
- Warning Systems and Mass Notification
  - <http://www.federalwarningsystems.com/>

### Public Safety and Security Industry:

- Department of Homeland Security (DHS)
  - <http://www.dhs.gov/index.shtm>
- National Incident Management Systems (NIMS)
  - <http://www.fema.gov/emergency/nims/index.shtm>

For additional information please visit Federal Signal at <http://www.federalsignal.com>